

# VISOCOLOR® Bodenkoffer

## VISOCOLOR®

Bodenkoffer

Reagent case for soil analysis

Mallette d'analyse du sol

Maletín para análisis de suelos

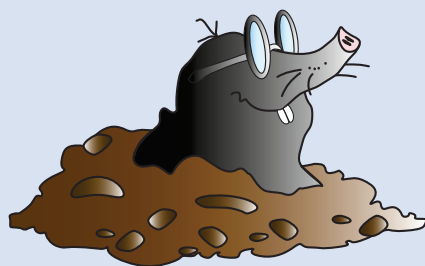

Handbuch  
Manual  
Manuel

**MACHEREY-NAGEL**

[www.mn-net.com](http://www.mn-net.com)



## Contents

<b>1. <i>VISOCOLOR</i><sup>®</sup> reagent case for soil analysis</b> .....	<b>24</b>
1.1 Analysis options .....	24
1.2 Content of the <i>VISOCOLOR</i> <sup>®</sup> reagent case for soil analysis (REF 931 601) .....	24
1.3 Content of the <i>VISOCOLOR</i> <sup>®</sup> reagent case for soil analysis with PF-3 (REF 934 220) .....	25
1.4 Working procedure .....	26
<b>2. Soil analysis procedure</b> .....	<b>27</b>
2.1 Sampling .....	27
2.2 Weighing and determination of moisture content.....	27
2.3 Sieving the soil sample.....	27
2.4 Determination of the soil density .....	27
2.5 Preparation of soil extract A .....	28
2.6 Determination of the pH value .....	28
2.7 Determination of nitrate and nitrite .....	29
2.8 Determination of ammonium .....	29
2.9 Preparation of soil extract B .....	29
2.10 Determination of phosphorus .....	30
2.11 Determination of potassium .....	30
2.12 Determination of soil type (sedimentation analysis) .....	31
<b>3. Procedure for photometric soil analysis</b> .....	<b>31</b>
3.1 Preparation of soil extract AF .....	31
3.2 Determination of pH value .....	31
3.3 Photometric determination of nitrate .....	32
3.4 Photometric determination of nitrite.....	32
3.5 Photometric determination of ammonium .....	32
3.6 Preparation of soil extract B .....	33
3.7 Photometric determination of phosphorus.....	33
3.8 Photometric determination of potassium .....	34
<b>4. Calculation and correction of results</b> .....	<b>35</b>
4.1 Correction of moisture content .....	35
4.2 Calculation referring to areas .....	35
4.3 Conversion into different dimensions .....	35

## 1. VISOCOLOR® reagent case for soil analysis

This portable laboratory contains all reagents, instruments and accessories required for the preparation of soil extracts and the subsequent analysis of phosphate (P), potassium (K), ammonium, nitrate, nitrite (N), soil structure and pH.

The complete case has been designed for rapid, convenient and reliable soil analysis, both in the lab or in the field. In addition to the variation for colorimetric evaluation, the reagent case is also available with the compact photometer PF-3. Prior to the analysis, the components of the soil sample must be converted into an aqueous form by extraction with calcium chloride solution or calcium-acetate-lactate solution. If required by national regulations or geological conditions, the reagents and accessories can also be used together with extraction solutions other than those included in the case; in this case please observe dilution factors. The measurements are carried out either with colorimetric rapid tests or with easy to use test strips or photometric with the PF-3. These analytical methods provide a sufficient accuracy for rapid determination of nutrients in soil. In addition, the soil extracts can also be analyzed with NANOCOLOR® photometers. NANOCOLOR® reagents and photometers are not supplied in this reagent case, but can be ordered separately.

### 1.1 Analysis options

#### Extraction solutions

- Soil extract A  
(for pH, ammonium, nitrite, nitrate):
  - 1 liter extraction solution A + 100 mL CaCl<sub>2</sub> stock solution, sufficient for 110 soil samples
  - Refill pack REF 914 612  
3 x 100 mL CaCl<sub>2</sub> stock solution, sufficient for 300 soil samples
- Soil extract B  
(for potassium and phosphorus):
  - 1 liter extraction solution B + 100 mL CAL stock solution, sufficient for 7 soil samples
  - Refill pack REF 914 614  
4 x 100 mL stock solution, sufficient for 10 soil samples

Individual parameters	Analysis	REF
QUANTOFIX® Ammonium	100 refill pack	913 15
QUANTOFIX® Nitrate / Nitrite	100 refill pack	913 13
VISOCOLOR® ECO Ammonium 3	50 refill pack	931 208
VISOCOLOR® ECO Nitrate	110 refill pack	931 241
VISOCOLOR® ECO Phosphate	80 refill pack	931 284
VISOCOLOR® ECO Potassium	60 refill pack	931 232
VISOCOLOR® HE pH	500 refill pack	920 174
VISOCOLOR® HE Phosphorus	100 refill pack	920 183

## 1.2 Content of the VISOCOLOR® reagent case for soil analysis (REF 931 601)

The VISOCOLOR® reagent case for soil analysis includes the following:

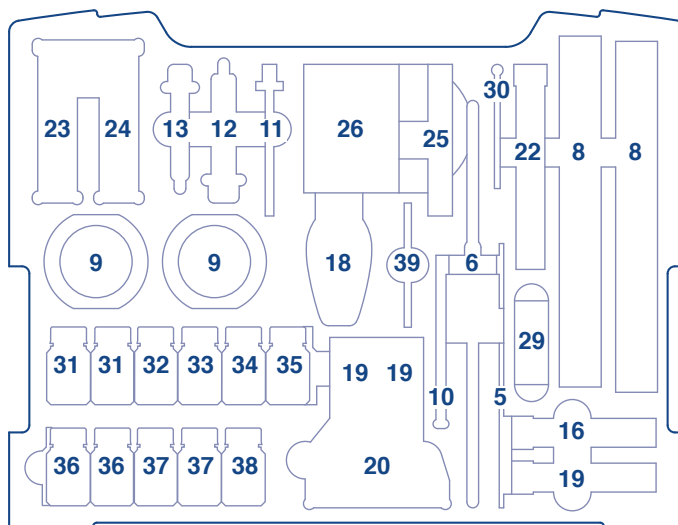

Upper inlay

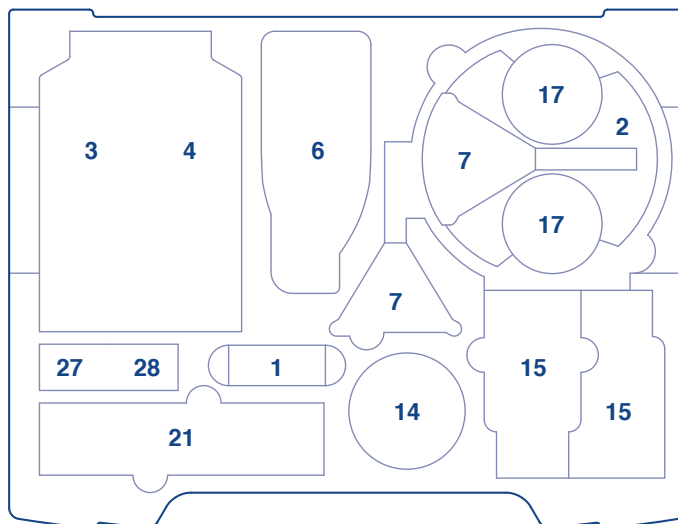

Lower inlay

## 1.3 Content of the VISOCOLOR® reagent case for soil analysis with PF-3 (REF 934 220)

The VISOCOLOR® reagent case for soil analysis with PF-3 includes the following:

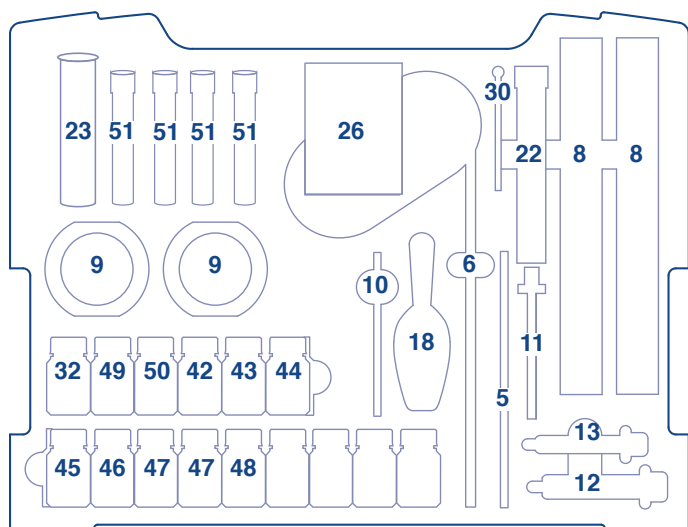

Upper inlay

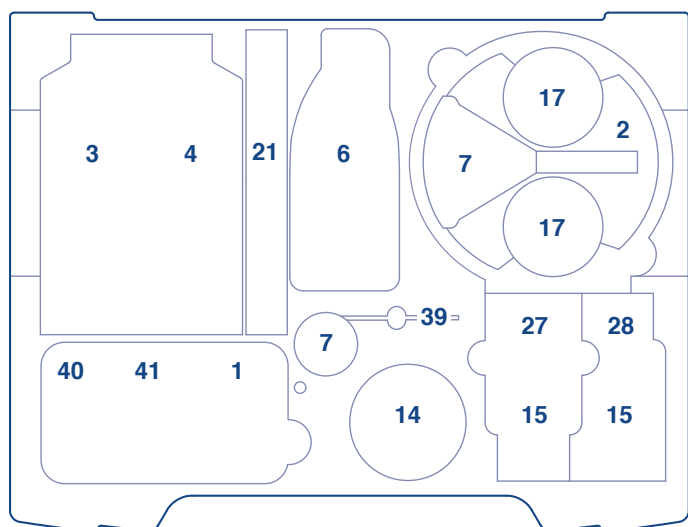

Lower inlay

No.	Item	REF
1	Balance	914 651
2	Soil sieve	914 650
3	Extraction solution B (CAL solution)	–
4	Extraction solution A (CaCl <sub>2</sub> solution)	–
5	Metal double spatula	916 94
6	Storage and squeeze bottle for distilled water	916 89
7	Funnels 80 mm diameter	914 657
8	Measuring cylinders 100 mL	914 655
9	Stands for measuring cylinders	
10	Glass stamper (for sedimentation analysis)	–
11	Syringe 1 mL with tip	914 662
12	Syringe 10 mL	914 660
13	Syringe 5 mL	914 661
14	Wide neck bottle 500 mL for soil samples	914 653
15	Shaking bottles 300 mL	914 654
16	Sample tube for potassium analysis	914 496
17	Beakers 250 mL for soil weighing	914 652
18	Plastic scoops	914 656
19	HE measuring tubes for pH and phosphorus	920 401
20	HE comparator block for pH and phosphorus	920 402
21	Folded filters MN 616 ¼	532 018
22	Sedimentation tube	914 659
23	Test strips QUANTOFIX® Nitrate/Nitrite	913 13
24	Test strips QUANTOFIX® Ammonium	913 15
25	Measuring tube for potassium	914 444
26	pH-Fix 2.0–9.0	921 18
27	CAL stock solution	914 614
28	CaCl <sub>2</sub> stock solution	914 612
29	Sample tube for ammonium	915 499
30	Measuring spoon for potassium analysis	914 663
31	Reagent Ammonium-1	913 15
32	Pyrophosphate solution	914 611
33	Reagent HE Phosphate P-1	920 183
34	Reagent HE Phosphate P-2	
35	Reagent HE Phosphate P-K	
36	Reagent HE pH 4–10	920 074
37	Reagent ECO Potassium-1	920 032
38	Reagent ECO Potassium-2	
39	Syringe tube	–
40	Photometer PF-3, version E	
41	Batteries for PF-3	
42	Reagent ECO Ammonium-1	931 208
43	Reagent ECO Ammonium-2	
44	Reagent ECO Ammonium-3	
45	Reagent ECO Nitrate-1	931 241
46	Reagent ECO Nitrate-2	
47	Reagent ECO Potassium-1	931 232
48	Reagent ECO Potassium-2	
49	Reagent ECO Phosphate-1	931 284
50	Reagent ECO Phosphate-2	
51	Reaction tube 16 mm OD	916 80

## 1.4 Working procedure

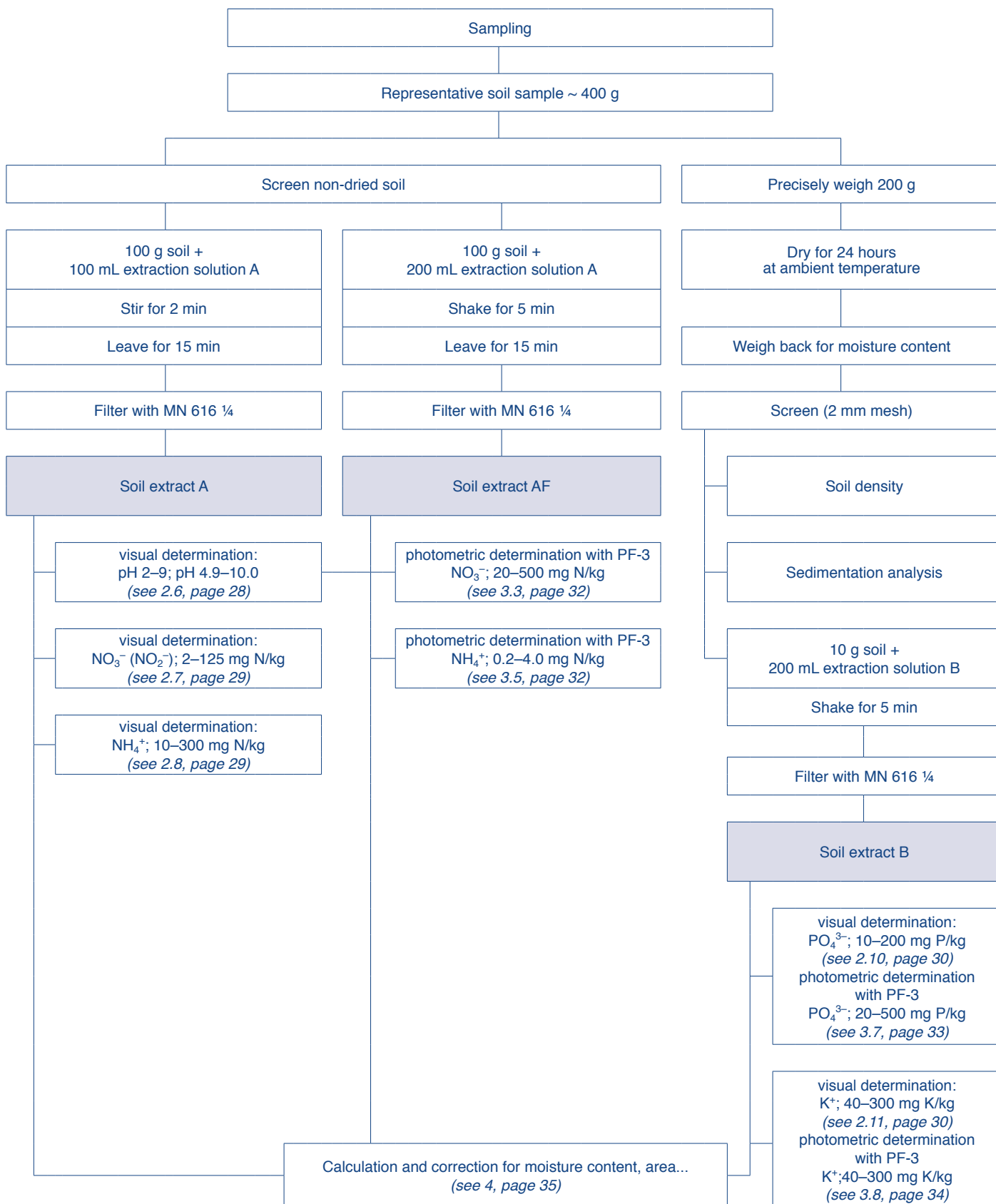

## 2. Soil analysis procedure

### 2.1 Sampling

Take several samples from various locations of the area to be examined and mix them. Do not take samples after prolonged or strong rainfall. Soil from arable land should be taken after the harvest and prior to fertilizing. Grassland can be analyzed in spring and winter or after each cut. The sampling depth is 10 cm for lawns and grassland, 15–30 cm for arable land and 30 cm for vegetable beds and shrub areas.

The samples can be taken with a spade; soil drills are required for examining the deeper layers of soil at depths of 30–60 cm and 60–90 cm.

Prior to the analysis, remove all untypical parts such as stones, parts of plants and other items (glass, metal, pieces of plastic, etc.).

The sample is then weighed and dried, and the moisture content and density of the soil are determined (see 2.2, page 27, see 2.4, page 27).

### 2.2 Weighing and determination of moisture content

1. Set up balance (1)
2. Place plastic beaker (17) on the balance pan
3. Tare to ZERO
4. Weigh the required quantity of soil with the aid of the plastic scoop (18)

#### Determination of moisture content:

Weigh 200 g of the soil sample and spread evenly over one of the cardboard sheets (210 x 297 mm). Crush any large clumps of soil and dry in a well-ventilated room at room temperature for 16–24 hours.

After drying, pour the soil sample back into the tared measuring beaker and establish its weight.

Calculation of the moisture content of the soil.

$$\frac{\text{Weight of moist soil [g]} - \text{Weight of dry soil [g]}}{\text{Weight of moist soil [g]}} \times 100 = \% \text{ soil moisture}$$

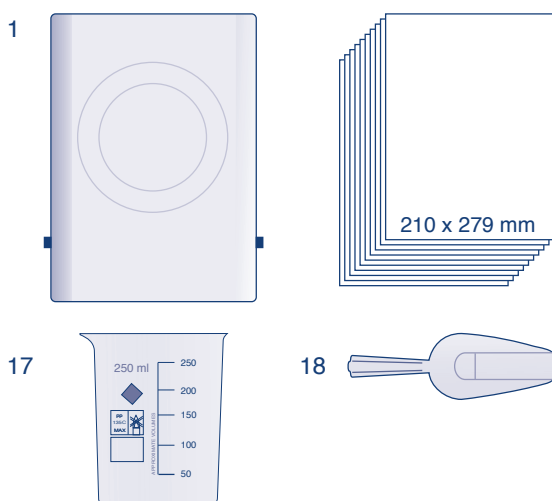

### 2.3 Sieving the soil sample

Prior to the preparation of the soil extracts and the determination the soil density and soil structure (sedimentation) of the sample is screened. The mesh width is 2 mm. This means that all particles larger than 2 mm are removed from the sample. Analytical values from screened samples provide improved comparability,

as the accuracy and precision of the individual examination are increased.

Place the air-dry sample on the sieve (2) in portions, carefully crushing large clumps of earth beforehand. Screen the soil onto a clean cardboard sheet 210 x 297 mm. Discard the material retained by the sieve. The material obtained in this manner is used to prepare the soil extracts.

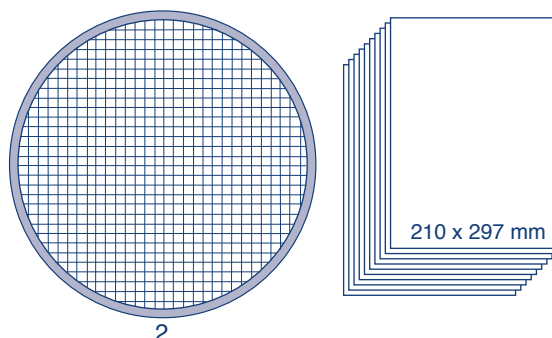

### 2.4 Determination of the soil density

Soils consist of grains of varying sizes and shapes. The specific weights of the constituent parts, and the pore volume result in the soil density (kg/dm³). We determine the soil density on the basis of the air-dry, screened soils.

#### Procedure:

Insert the 100 mL measuring cylinder (8) into the green plastic base (9). Place the cylinder onto the balance (1) and write down its weight. Take the cylinder off the balance and fill with sieved soil using the plastic shovel (18). Compact the soil by gently tapping the cylinder on a solid surface until the 100 mL mark is reached, or read the respective volume. If necessary, level the surface without exerting any pressure (in case the soil quantity is not sufficient, write down the respective volume). Place measuring cylinder on the balance and read weight.

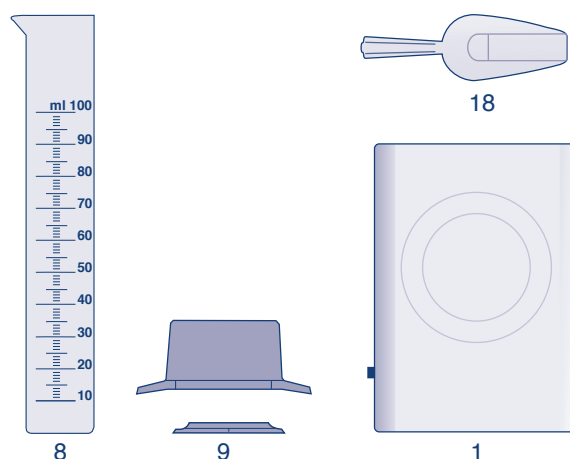

#### Calculation:

$$D \left[ \frac{\text{kg}}{\text{dm}^3} \right] = \frac{A [\text{g}]}{V [\text{mL}]}$$

A = Soil weight

D = Soil density

V = Volume

## 2.5 Preparation of soil extract A

Soil extract A, which is prepared with extraction solution A (calcium chloride solution, 0.0125 mol/dm<sup>3</sup>), is used to analyze pH value, ammonium, nitrite and nitrate.

### Preparation of the extraction solution:

Using the plastic syringe (12), transfer 10 mL of the CaCl<sub>2</sub> stock solution (28) into the bottle for extraction solution A (4) add 1 L of distilled water (6) and mix.

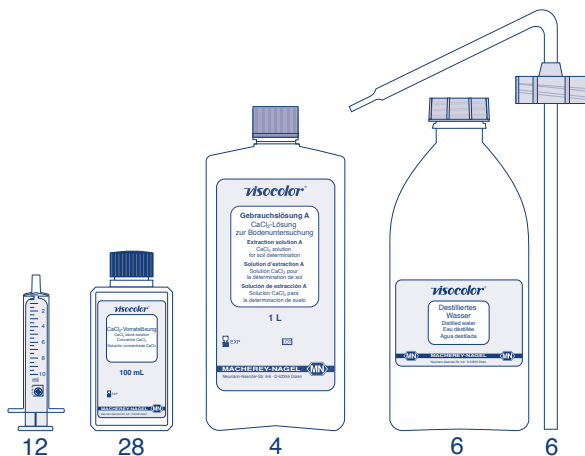

### Preparation of the soil extract:

Soil extract A is produced from the **non-dried** soil sample. The soil sample should not be too wet and – if possible – it should be screened. Remove all coarse and untypical constituents. In a plastic beaker (17), weigh out 100 g of the soil sample, which was prepared as described above. Add 100 mL of extraction solution A (4). Stir vigorously with the metal spatula (5) for 2 min, leave to stand for 15 min, while stirring again several times during this period.

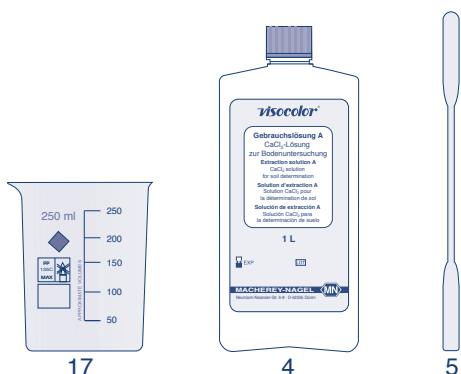

Place a funnel (7) on a 100 mL measuring cylinder (8), insert a folded filter MN 616 ¼ (21). Pour the suspension into the folded filter. If the filtrate is too cloudy at the beginning of filtration, pour it back into the filter. With certain soils, slight coloration or clouding is unavoidable. This will not affect the determinations described below. Should it prove impossible to filter particularly problematic soils due to high silt or clay content, we recommend the following procedure: Pour the suspension into the measuring cylinder, leave to stand for a prolonged period (e.g. overnight) and use the clear or slightly turbid supernatant for analysis (remove with syringe 10 mL, fitting the enclosed tube section (39) on the syringe (12) beforehand. Rinse syringe several times with water afterwards).

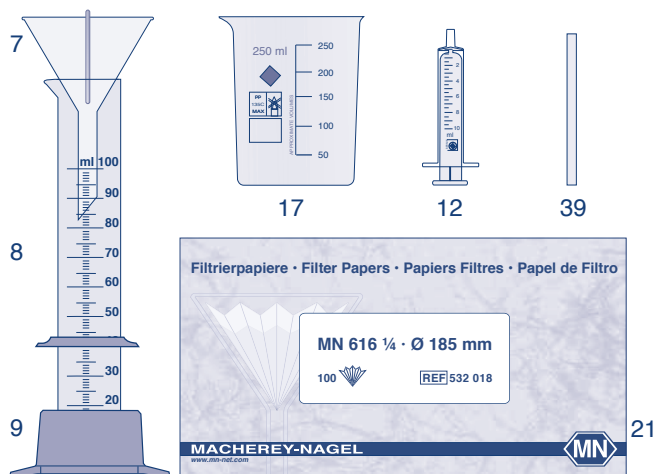

## 2.6 Determination of the pH value

The pH value is determined in soil extract A using colorimetry or pH indicator strips.

### Procedure:

Insert the color disc pH 4.0–10.0 into the VISOCOLOR® HE comparator block (20). Fill both measuring glasses (19) up to the ring mark with soil extract A and place them in the comparator block (if the soil extract is colorless, the glass on the left can be filled with clear water). Add 4 drops of pH 4–10 (36) to the right glass, close and mix. Look through the glasses from above, compare the colors of the two glasses and turn the color disc until the colors match. Read off the result from the marking on the front side of the comparator block. Intermediate values can be estimated. After use, rinse both round glasses thoroughly and close.

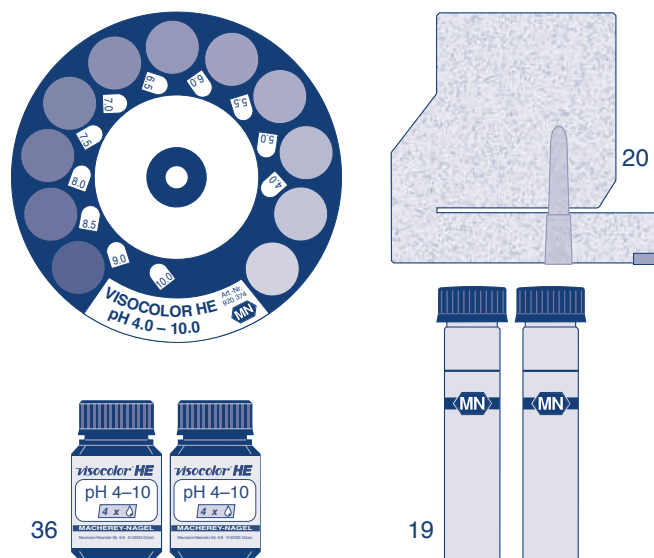

When pH values of less than 4.5 are measured, an additional measurement is carried out with pH-Fix 2.0–9.0 test strips (26).

Fill a test tube with ring mark (29) with soil extract A to a height of approx. 3 cm, insert pH test strip in the sample. After 5 min, remove the test strip and compare with the color scale, read off pH value.

*Note: For measurements with an electrometric pH meter, a special soil extract A is prepared in the ratio 2 + 5, e.g. 20 g soil + 50 mL extraction solution A. You may also use soil extract AF (see 3.1, page 31).*

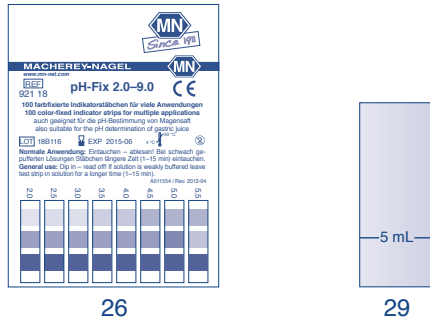

## 2.7 Determination of nitrate and nitrite

The nitrate/nitrite concentration is determined in soil extract A using QUANTOFIX® Nitrate/Nitrite test strips (23).

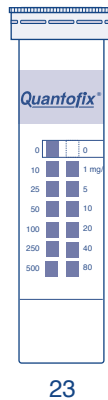

### Procedure:

Dip the test strip in soil extract A for approx. 1 s. After 60 s, compare the test field against the color scale. If nitrate or nitrite are present, the test field turns pink.

The outer test field (at the end of the stick) indicates the nitrate content, the inner test field indicates the nitrite content.

*Please note: Reclose the package tightly immediately after use. Do not touch the test fields with fingers.*

### Calculation of results:

Read off result of nitrate in mg/L  $\text{NO}_3$  and multiply with 0.23 to receive the result in mg/kg N.

e.g.  $100 \text{ mg/L NO}_3 \times 0.23 = 23.0 \text{ mg/kg N}$

Read off result of nitrite in mg/L  $\text{NO}_2$  and multiply with 0.30 to receive the result in mg/kg N.

## 2.8 Determination of ammonium

The ammonium nitrogen content is determined in soil extract A using QUANTOFIX® Ammonium test strips (24).

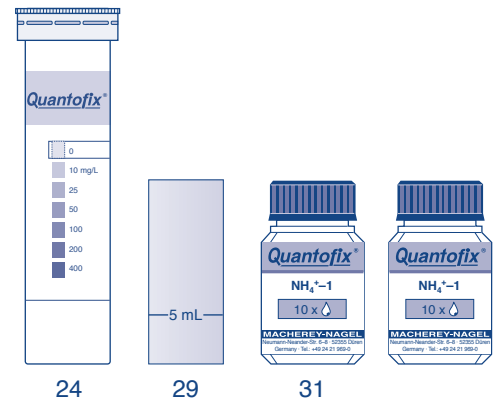

### Procedure:

Fill the test tube (29) with soil extract A up to the 5 mL mark. Add 10 drops of  $\text{NH}_4^{+}-1$  (31) and swirl carefully. Dip the test strip in the prepared test solution for 5 s. Compare test field with color scale, read off measured value. If ammonium is present, the test paper turns brown.

*Close ammonium vial immediately after removing the test strip. Do not touch the test field with fingers.*

### Calculation of results:

Read off result of ammonium in mg/L  $\text{NH}_4$  and multiply with 0.78 to receive the result in mg/kg N.

e.g.  $100 \text{ mg/L NH}_4 \times 0.78 = 78 \text{ mg/kg N}$

## 2.9 Preparation of soil extract B

Soil extract B, which is prepared with extraction solution B (CAL solution = calcium acetate lactate,  $0.05 \text{ mol/dm}^3$ ), is used to analyze phosphorus and potassium.

### Preparation of the extraction solution:

Pour 100 mL of the CAL stock solution (27) into the bottle for extraction solution B (3), add 0.4 L of distilled water (6) and mix (or mix 2 x 100 mL CAL stock solution (refill) with 800 mL dist. water).

*Note: Should flocs or precipitates occur in the extraction solution B, the solution is to be discarded. Rinse the bottle several times with hot water and prepare fresh solution.*

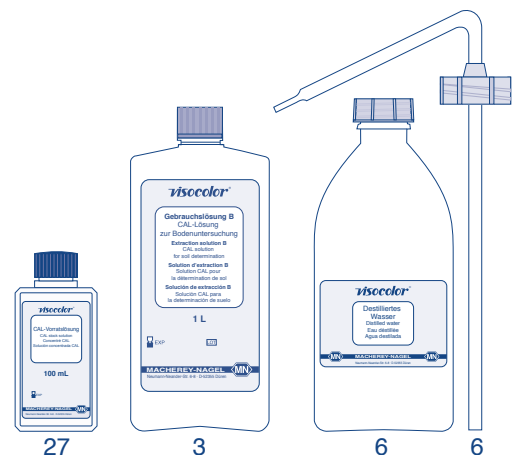

### Preparation of the soil extract:

Normally, the soil should be dried at  $105 \text{ }^\circ\text{C}$  for the purpose of removing the soil water. However, since a drying oven will rarely be available, it is sufficient to dry the soil overnight at room tempera-

ture. Weigh out 10 g of the air-dried, screened soil in a shaking bottle (15). Add 200 mL of extraction solution B with the aid of the measuring cylinder (8) and close shaking bottle. Shake bottle vigorously for 5 min, allow solid matter to settle briefly. Place plastic funnel (7) in a 100 mL measuring cylinder (8), insert a folded filter MN 616 ¼ (21). Filter suspension. If the solution is initially turbid, pour it back into the folded filter. A slightly yellow inherent color of soil extract B will not affect the following analysis.

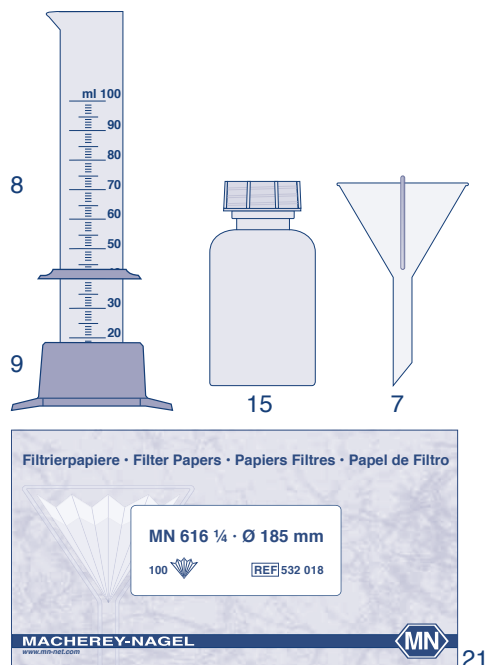

## 2.10 Determination of phosphorus

Phosphorus analysis is carried out with a colorimetric test kit or photometric under use of the kit VISOCOLOR® ECO Phosphate (see 3.7).

### Procedure:

Place two measuring tubes (19) in the comparator block (20), insert color disc. With the aid of the 1 mL plastic syringe (11) transfer 1.6 mL of soil extract B into each of the measuring tubes and fill to marking line with distilled water. Add 6 drops of P-1 (33) to the right glass, mix. Add 6 drops of P-2 (34) to the right glass, mix. Add 6 drops of P-K (35) to the left glass, mix.

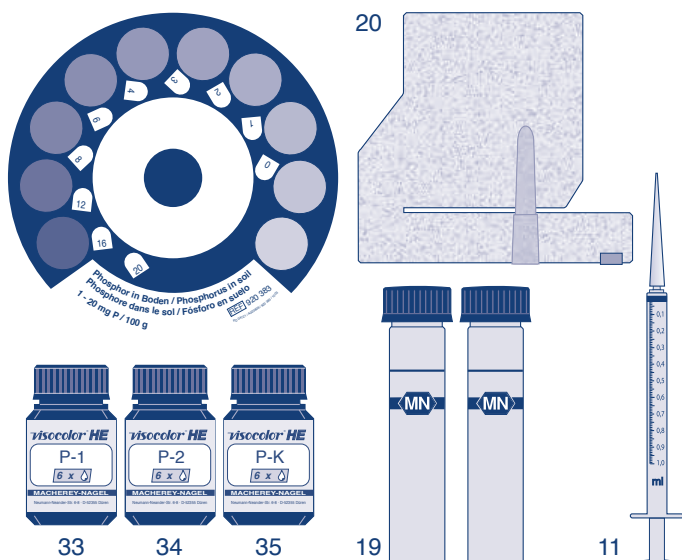

After 10 min: look through the glasses from above, compare the colors of the two glasses and turn the color disc until the colors match. Read off the measurement value from the marking on the front side of the comparator block. Intermediate values can be estimated.

After use, rinse thoroughly and close. Do not use any rinsing agent containing phosphate to clean the measuring tubes.

### Calculation of results:

Read off result of phosphorus in mg/100 g P and multiply with 10 to receive the result in mg/kg P.

e.g. 6 mg/100 g P x 10 = 60 mg/kg P

## 2.11 Determination of potassium

Potassium is analyzed nephelometrically, i.e. the turbidity caused by the potassium is measured. The turbidity measurement can be done as described below visual or photometric (see 3.8)

### Procedure:

Fill a clean sample tube for potassium (16) with soil extract B up to the ring mark (16.8 mL). Add 15 drops of K-1 (37) to the sample tube, close and mix. Add a flat measuring spoon (30) of K-2 (38) to the sample tube, close and shake, not too vigorously, for approx. 30 s (no reagent residues should be visible at the bottom of the sample tube after shaking).

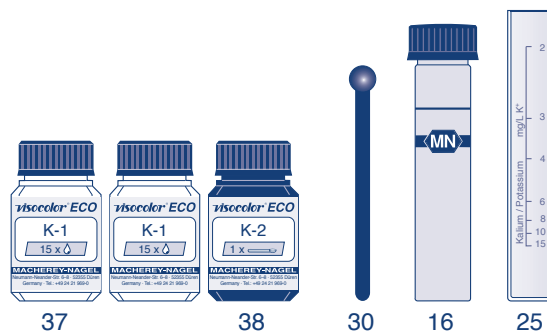

Pour the liquid from the sample tube into the potassium measuring tube (25) until the black cross at the bottom of the measuring tube becomes invisible (when looking into the tube from above).

Read the potassium content from the scale of the measuring tube (meniscus bottom edge).

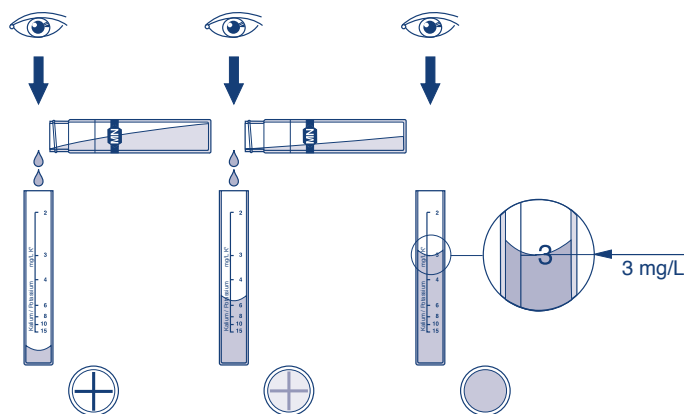

### Calculation of results:

Read off result of potassium in mg/L K and multiply with 20 to receive the result in mg/kg K.

e.g. 3 mg/L K x 20 = 60 mg/kg K

## Forest sedimentation analysis according to KRUEDENER

### 2.12 Determination of soil type (sedimentation analysis)

#### Procedure:

A soil sample is crumbled with the fingers in the screen and coarse contents (stones, etc.) are removed. The crushed sample is placed in the test glass (22) and compressed a little with the glass stamper (10). There must be sufficient soil in the test glass to reach the **E** mark. If necessary, the test glass must be knocked several times in the flat of the hand. The glass is then filled with water up to the **F** mark below the top of the glass. The addition of 10 drops of pyrophosphate solution (32) prevents flocculation of the clay particles.

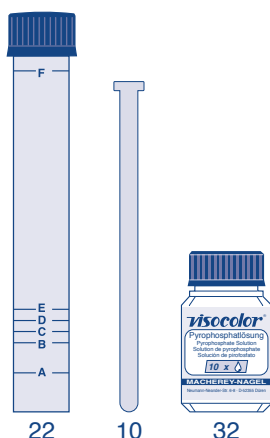

The glass is closed with the screw cap and shaken thoroughly until soil and water are evenly dispersed. When very loamy soils are involved, the samples are first of all “softened” and then shaken thoroughly. Shaking is then stopped suddenly and the test glass is positioned vertically.

After 18 s, the sand particles have sedimented; the height of the sand fraction will have reached one of the lower 4 marks after these 18 s. Read off the identification letter and refer to the table above to establish the soil type.

The closed test glasses can be checked again after a few days (particularly when heavy soils are involved), when the clay fractions have also settled. The separation of all the fractions in the glass is then to be seen very clearly. In this case, the volume ratio of the fractions “sand” and “elutriable matter” can also be determined more accurately.

**Example:** Filling height = E after 18 s = A mark

Evaluation: Sand: < 40 %  
 Elutriable matter: > 60 %  
 Soil type: Clay

### Classification of soil types according to the German soil estimation regulation [3] [6]

Mark	Sand (%)	Soil type
E	100–91	Sand
D	90–87	Slightly loamy sand
C	86–82	Loamy Sand
	81–77	Very loamy sand
B	76–71	Sandy loam
	70–54	Loam
A	55–40	Heavy loam
	40– 0	Clay

### 3. Procedure for photometric soil analysis

The VISOCOLOR® reagent case fully satisfies the requirements for rapid determination of nutrient supply and fertilizer requirement. Together with the VISOCOLOR® test kits the reagent case with PF-3 provides with quick and user-independent information on soil samples. For more extensive investigations, there is the possibility to use the PF-3 in combination with the NANOCOLOR® system.

The following chapters describe the preparation of soil extracts and the determination of ammonium, nitrate, potassium and phosphate with the PF-3. Further they give information about the use of other NANOCOLOR® photometers and NANOCOLOR® test kits\*.

#### 3.1 Preparation of soil extract AF

Soil extract AF, which is prepared with extraction solution A (calcium chloride solution, 0.0125 mol/dm<sup>3</sup>, see 2.5, page 28) is used to analyze pH value, ammonium, nitrite and nitrate. The composition of this soil extract differs from soil extract A.

#### Procedure:

Soil extract AF is produced from the non-dried soil sample, but it should not be too wet and it should, if possible, be screened. Remove all coarse and untypical constituents. Weigh out 100 g of the soil sample prepared in this manner in a shaking bottle. Add 200 mL of the extraction solution A with the aid of the measuring cylinder. Close shaking bottle. Shake bottle vigorously for 5 min, allow solid matter to settle briefly. Place plastic funnel in a measuring cylinder 100 mL, insert an MN 616 ¼ folded filter. Filter suspension. If the solution is initially cloudy, pour it back into the folded filter.

Filtrate = soil extract AF

#### 3.2 Determination of pH value

The pH value is determined in soil extract AF using colorimetry or pH indicator strips, a photometric determination of the soil pH is not possible.

#### Procedure:

Insert the pH 4.0–10.0 color disc in the VISOCOLOR® HE comparator block. Fill both measuring glasses up to the ring mark with soil extract AF and place them in the comparator (if the soil extract is colorless, the glass on the left can be filled with clear water). Add 4 drops of pH 4–10 to the right glass, close and mix. Look through the glasses from above, compare the colors of the two glasses and turn the color disc until the colors match. Read off the result from the marking on the front side of the comparator block. Intermediate values can be estimated. After use, rinse both round glasses thoroughly and close.

When pH values of less than 4.5 are measured, an additional measurement is carried out with pH-Fix 2.0–9.0 test strips.

Fill a test tube with ring mark with soil extract AF to a height of approx. 3 cm, insert pH test strip in the sample. After 5 min, remove the test strip and compare with the color scale, read off pH value.

\* The preprogrammed submethods (mg/kg and mg/100 g) for soil analysis in our NANOCOLOR® photometers account for all steps and dilutions in the sample preparation during the calculation of the measurement result and therefore only give reliable results using the methods and preparation steps described in this handbook. The amendments CAL (calcium acetate lactate) and AF (Soil extract AF) in the submethod names refer to the extraction solutions to be used. In case of changing the procedure, we recommend to use the submethod with the unit mg/L and a conversion to the desired unit for soil analysis by accounting for dilutions manually.

## 3.3 Photometric determination of nitrate

### Procedure with PF-3:

Measurement of nitrate nitrogen with reagent set VISOCOLOR® ECO nitrate and the PF-3:

Zero measurement with sample. Rinse test tube (51) and add 5 mL water sample using the plastic syringe (13). Add 5 drops NO<sub>3</sub>-1 (45) seal the glass and shake. Add 1 level measuring spoon of NO<sub>3</sub>-2 (46), seal the glass and shake well for 1 min. Clean outside of test tube and measure after 5 min with the PF-3 (40).

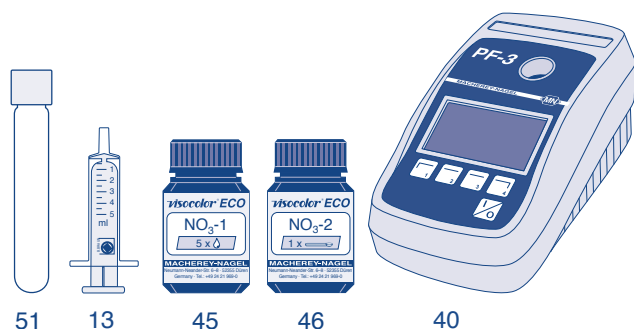

### Preprogrammed submethods:

Wavelength:	450 nm
Method 5411	1.0–14.0 mg/L NO <sub>3</sub> -N
Method 5412	4–60 mg/L NO <sub>3</sub> <sup>-</sup>
Method 5416	2–28 mg N/kg soil

Measurement of nitrate nitrogen with reagent set NANOCOLOR® Nitrate 50 (REF 985 064) and the PF-3:

Follow the instructions enclosed in the reagent set. In case of colored or turbid solutions prepare a blank value by adding 0.5 mL soil extract AF and 0.5 mL dist. water to a test tube.

### Preprogrammed submethods:

Wavelength:	365 nm
Method 0641	0.3–22.0 mg/L NO <sub>3</sub> -N
Method 0642	2–100 mg/L NO <sub>3</sub> <sup>-</sup>
Method 0644	1–44 mg N/kg soil

### Procedure with further NANOCOLOR® photometers

Measurement of nitrate nitrogen with reagent set NANOCOLOR® Nitrate 50 (REF 985 064):

Follow the instructions enclosed in the reagent set. In case of colored or turbid solutions prepare a correction value by adding 0.5 mL soil extract AF and 0.5 mL dist. water to an empty test tube and use the correction value function in the NANOCOLOR® photometer (see manual).

### Preprogrammed NANOCOLOR® photometers

NANOCOLOR® UV/VIS, VIS, 500 D, 400 D, 300 D, 250 D, PF-12

Wavelength	365 / 385 nm
Method	(0)644 1–44 mg N/kg soil
Method	(0)645 4.5–200 kg N/ha soil

### Other photometers

Wavelength	365 / 385 nm
Multiply displayed result in mg/L with 2:	1–44 mg N/kg soil
Multiply displayed result in mg/L with 9:	4.5–200 kg N/ha soil

## 3.4 Photometric determination of nitrite

Measurement of nitrite nitrogen with reagent set NANOCOLOR® Nitrite 2 (REF 985 068):

Follow the instructions enclosed in the reagent set.

### Preprogrammed photometers

NANOCOLOR® UV/VIS, VIS, 500 D, 400 D, 300 D, 250 D, PF-12	
Wavelength	540 nm
Method (0)683	0.02–0.9 mg N/kg soil

### Other photometers

Wavelength	540 nm
Multiply displayed result in mg/L N with 2:	0.02–0.9 mg N/kg soil

## 3.5 Photometric determination of ammonium

### Procedure with PF-3:

Measurement of ammonium with reagent set VISOCOLOR® ECO Ammonium 3 and the PF-3:

Zero measurement with sample. Rinse test tube (51) and add 5 mL water sample using the plastic syringe (13). Add 10 drops NH<sub>4</sub>-1 (42) seal the glass and shake. Add 1 level measuring spoon of NH<sub>4</sub>-2 (43) seal the glass and shake the mixture until the powder has dissolved. Wait for 5 min. Add 4 drops NH<sub>4</sub>-3 (44). Seal the glass and shake. Clean outside of test tube and measure after 5 min with the PF-3 (40).

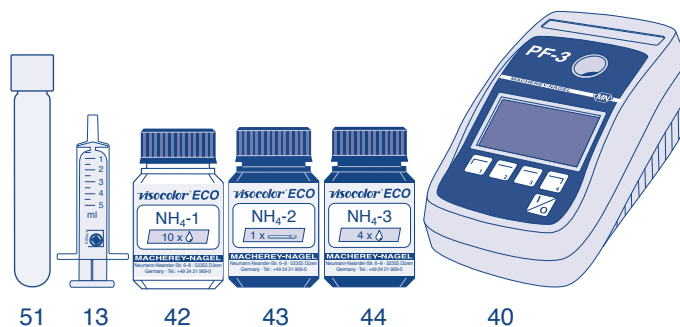

### Preprogrammed submethods:

Wavelength:	660 nm
Method 5081	0.1–2.0 mg/L NH <sub>4</sub> -N
Method 5082	0.1–2.5 mg/L NH <sub>4</sub>
Method 5086	0.2–4.0 mg N/kg soil

Measurement of ammonium nitrogen with the reagent sets NANOCOLOR® Ammonium 3/10/50 (REF 985 003/985 004/985 005) and the PF-3:

Follow the instructions enclosed in the reagent set. If soil extract AF is turbid, it must be filtered with a 0.45 µm membrane filter (REF 916 50) prior to analysis. The selection of the test depends on the ammonium content to be expected. For higher contents, use the test 0-05, for lower levels test 0-04.

## Preprogrammed submethods:

Wavelength:	660 nm
Method 0031	0.04–2.30 mg/L NH <sub>4</sub> -N
Method 0032	0.05–3.00 mg/L NH <sub>4</sub>
Method 0036	0.08–4.60 mg N/kg soil
Method 0041	0.2–8.0 mg/L NH <sub>4</sub> -N
Method 0042	0.2–10.0 mg/L NH <sub>4</sub>
Method 0046	0.4–16.0 mg N/kg soil
Method 0051	1.0–40.0 mg/L NH <sub>4</sub> -N
Method 0052	1.0–50.0 mg/L NH <sub>4</sub>
Method 0056	2.0–80.0 mg N/kg soil

## Procedure with further NANOCOLOR® photometers

Measurement of ammonium nitrogen with the reagent sets NANOCOLOR® Ammonium 10/50 (REF 985 004/985 005):

Follow the instructions enclosed in the reagent set. If soil extract AF is turbid, it must be filtered with a 0.45 µm membrane filter (REF 916 50) prior to analysis. The selection of the test depends on the ammonium content to be expected. For higher contents, use the test 0-05, for lower levels test 0-04.

## Preprogrammed NANOCOLOR® photometers

NANOCOLOR® UV/VIS, VIS, 500 D, 400 D, 300 D, 250 D, PF-12

Wavelength	690 nm
Test 0-04	Method (0)046      0.4–16 mg N/kg soil Method (0)047      1.8–72 kg N/ha soil
Test 0-05	Method 0056 (bar-code reading photometers) or 048      2–80 mg N/kg soil Method 0057 (bar-code reading photometers) or 049      9–360 kg N/ha soil

## Other photometers

Wavelength	690 nm
Test 0-04	Multiply displayed result in mg/L with 2: 0.4–16 mg N/kg soil
Test 0-05	Multiply displayed result in mg/L with 2: 2–80 mg N/kg soil

## 3.6 Preparation of soil extract B

Soil extract B, which is prepared with extraction solution B (CAL solution = calcium acetate lactate, 0.05 mol/dm<sup>3</sup>), is used to analyze phosphorus and potassium.

### Preparation of the extraction solution:

Pour 2 x 100 mL of the CAL stock solution into the bottle for extraction solution B, add 0.8 L of distilled water and mix (or mix 100 mL CAL stock solution with 400 mL distilled water).

*Note: Should flocs or precipitates occur in the extraction solution B, the solution is to be discarded. Rinse the bottle several times with hot water and prepare fresh solution.*

### Preparation of the soil extract:

Normally, the soil should be dried at 105 °C for the purpose of removing the soil water. However, since a drying oven will rarely be available, it is sufficient to dry the soil overnight at room temperature. Weigh out 10 g of the air-dried, screened soil in a shaking bottle. Add 200 mL of extraction solution B with the aid of the measuring cylinder, close shaking bottle. Shake bottle vigorously for 5 min, allow solid matter to settle briefly. Place plastic funnel in a 100 mL measuring cylinder, insert a folded filter MN 616 ¼. Filter suspension. If the solution is initially turbid, pour it back into the folded filter. A slightly yellow inherent color of soil extract B will not affect the following analysis.

## 3.7 Photometric determination of phosphorus

### Procedure with PF-3:

Measurement of phosphorus with reagent set VISOCOLOR® ECO Phosphate and the PF-3:

The use of the VISOCOLOR® ECO Phosphate test kit needs for a dilution of extract B (1+4). Zero measurement with sample. Rinse test tube (51) and add 5 mL water sample using the plastic syringe (13). Add 6 drops PO<sub>4</sub>-1 (49), seal the glass and shake. Add 6 drops PO<sub>4</sub>-2 (50), seal the glass and shake. Clean outside of test tube and measure after 10 min with the PF-3 (40).

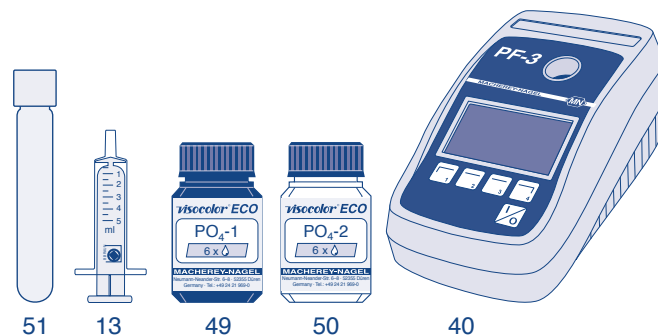

### Preprogrammed submethods:

Wavelength:	660 nm
Method 5841	0.2–5.0 mg/L PO <sub>4</sub> -P*
Method 5842	0.6–15.0 mg/L PO <sub>4</sub> *
Method 5847	5–115 mg/100g P <sub>2</sub> O <sub>5</sub>
Method 5849	20–500 mg P/kg soil

Measurement of phosphorus with reagent set NANOCOLOR® Phosphate 5/15 (REF 985 081/985 080) and the PF-3:

Follow the instructions enclosed in the reagent set.

### Preprogrammed submethods

Wavelength:	660 nm
Method 0801	0.30–15.00 mg/L P (total-Phosphate)
Method 0802	1.0–45.0 mg/L PO <sub>4</sub> (total-Phosphate)
Method 0803	0.7–34.5 mg/L P <sub>2</sub> O <sub>5</sub> (total-Phosphate)
Method 0804	0.7–34.5 mg/L P <sub>2</sub> O <sub>5</sub> (ortho-Phosphate)
Method 0805	0.30–15.00 mg/L PO <sub>4</sub> -P (ortho-Phosphate)
Method 0806	1.0–45.0 mg/L PO <sub>4</sub> <sup>3-</sup> (ortho-Phosphate)
Method 0807	1.4–69.0 mg/100g P <sub>2</sub> O <sub>5</sub> (CAL)
Method 0808	60–1560 kg/ha (CAL)
Method 0809	6–300 mg P/kg soil (CAL)
Method 0811	0.20–5.00 mg/L P
Method 0812	0.5–15.0 mg/L PO <sub>4</sub> <sup>3-</sup>
Method 0815	0.20–5.00 mg/L PO <sub>4</sub> -P (ortho-Phosphate)
Method 0816	0.5–15.0 mg/L PO <sub>4</sub> <sup>3-</sup> (ortho-Phosphate)
Method 0817	0.9–23.0 mg/100 g P <sub>2</sub> O <sub>5</sub> (CAL)
Method 0819	4–100 mg P/kg soil (CAL)

\*In case of using this submethods for soil analysis, the dilution has to be corrected manually.

## Procedure with further NANOCOLOR® photometers

Messung des Phosphors mit dem Reagenziensatz NANOCOLOR® Phosphate 15 (985 080):

Follow the instructions enclosed in the reagent set.

## Preprogrammed NANOCOLOR® photometers

NANOCOLOR® <sup>UV</sup>/<sub>VIS</sub>, VIS, 500 D, 400 D, 300 D, 250 D, PF-12

Wavelength 690 nm

Method (0)807 1.4–69 mg P<sub>2</sub>O<sub>5</sub>/100 g soil

Multiply displayed result with 4.3:

6–300 mg P/kg soil)

Method (0)808 60–1560 kg P<sub>2</sub>O<sub>5</sub>/ha soil

## Other photometers

Wavelength 690 nm

Multiply displayed result in mg/L with 46:

14–690 mg P<sub>2</sub>O<sub>5</sub>/kg soil

Multiply displayed result in mg/L with 20:

6–300 mg P/kg soil

## Preprogrammed NANOCOLOR® photometers

NANOCOLOR® <sup>UV</sup>/<sub>VIS</sub>, VIS, 500 D, 400 D, 300 D, 250 D, PF-12

Wavelength 690 nm

Method (0)452 5–120 mg K<sub>2</sub>O/100 g soil

Multiply displayed result with 8.3:

40–1000 mg K/kg soil

## Other photometers

Wavelength 690 nm

Multiply displayed result in mg/L with 24:

50–1200 mg K<sub>2</sub>O/kg soil

Multiply displayed result in mg/L with 20:

40–1000 mg K/kg soil

## 3.8 Photometric determination of potassium

### Procedure with PF-3:

Measurement of potassium with reagent set VISOCOLOR® ECO Potassium and the PF-3:

Zero measurement with sample. Rinse test tube (51) and add 10 mL water sample using the plastic syringe (13). Add 15 drops K-1 (47) seal the glass and shake. Add 1 level measuring spoon of K-2 (48) seal the glass and shake the mixture until the powder has dissolved. Seal the glass and shake constantly for 30 s until the powder has dissolved. Clean outside of test tube and measure with the PF-3 (40).

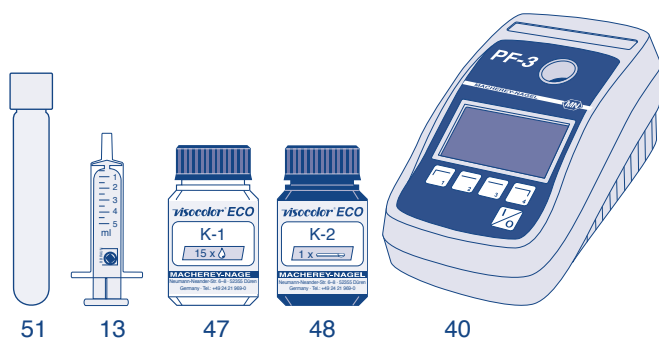

### Preprogrammed submethods:

Wavelength: 660 nm

Method 5321 2–15 mg/L K soil

Method 5326 40–300 mg K/kg soil

Method 5327 5–36 mg/100 g K<sub>2</sub>O

Measurement of potassium with reagent set NANOCOLOR® Potassium 50 (REF 985 045):

Follow the instructions enclosed in the reagent set.

### Preprogrammed submethods

Wavelength: 660 nm

Method 0451 2–50 mg/L K

Method 0456 40–1000 mg K/kg soil

Method 0457 5–120 mg/100 g K<sub>2</sub>O

