

CTD-10

Electrical Conductivity, Temperature & Depth Sensor

Operator's Manual



Decagon Devices, Inc.

Version: December 4, 2014 — 09:49:49

Decagon Devices, Inc.
2365 NE Hopkins Court
Pullman WA 99163

Phone: 509-332-5600

Fax: 509-332-5158

Website: www.decagon.com

Email: support@decagon.com or sales@decagon.com

©2012-2014 Decagon Devices, Inc.
All Rights Reserved

Contents

1	Introduction	1
1.1	Warranty	1
1.2	Seller's Liability	2
2	About CTD	3
2.1	Specifications	3
3	Theory	6
3.1	Water Depth	6
3.2	Temperature	6
3.3	Electrical Conductivity	6
4	Calibration	8
5	Connecting Sensors	9
5.1	Connection	9
5.2	Wiring	10
6	Communication	13
6.1	Decagon Serial String	13
6.2	SDI-12 communication	13
7	Installation	16
7.1	Taking a Reading	17
8	Maintenance and Troubleshooting	18
8.1	EC Sensor Cleaning	18
8.2	Troubleshooting	18
9	Declaration of Conformity	20

1 Introduction

Thank you for choosing Decagon's CTD Water Depth, Electrical Conductivity (EC), and Temperature sensor. This manual can help you understand the sensor features and ensure successful sensor operation. We hope you find the contents of this manual useful in understanding your instrument and maximizing its benefit to you.

There are several ways to contact Decagon if you ever need assistance with your product, have any questions, or feedback. Decagon has Customer Service Representatives available to speak with you Monday through Friday, between 7am and 5pm Pacific time.

Note: If you purchased your sensor through a distributor, please contact them for assistance.

Email:

support@decagon.com or **sales@decagon.com**

Phone:

509-332-5600

Fax:

509-332-5158

If contacting us by email or fax, please include as part of your message your instrument serial number, your name, address, phone, fax number, and a description of your problem or question.

Please read these instructions before operating your sensor to ensure that it performs to its full potential.

1.1 Warranty

The sensor has a 30-day satisfaction guarantee and a one-year warranty on parts and labor. Your warranty automatically validates upon receipt of the instrument.

1.2 Seller's Liability

Seller warrants new equipment of its own manufacture against defective workmanship and materials for a period of one year from the date of receipt of equipment.

Note: We do not consider the results of ordinary wear and tear, neglect, misuse, accident as defects.

The Seller's liability for defective parts shall in no event exceed the furnishing of replacement parts "freight on board" the factory where originally manufactured. Material and equipment covered hereby which is not manufactured by Seller shall be covered only by the warranty of its manufacturer. Seller shall not be liable to Buyer for loss, damage or injuries to persons (including death), or to property or things of whatsoever kind (including, but not without limitation, loss of anticipated profits), occasioned by or arising out of the installation, operation, use, misuse, nonuse, repair, or replacement of said material and equipment, or out of the use of any method or process for which the same may be employed. The use of this equipment constitutes Buyer's acceptance of the terms set forth in this warranty. There are no understandings, representations, or warranties of any kind, express, implied, statutory or otherwise (including, but without limitation, the implied warranties of merchantability and fitness for a particular purpose), not expressly set forth herein.

2 About CTD

The CTD sensor monitors water level, electrical conductivity, and temperature in both ground water and surface water. The Decagon CTD sensor uses a vented differential pressure transducer to measure the pressure from the water column to determine water depth. A thermistor in thermal contact with the probe provides water temperature, while the screws on the surface of the sensor form a four-electrode array to measure electrical conductivity. With a range of 0 to 120 dS/m, the CTD sensor has the ability to make accurate electrical conductivity measurements in a broad range of applications.

2.1 Specifications

CTD Calibration Values

Water Depth

Accuracy: 0.05% of f.s. @ 20 °C

Resolution: 2 mm

Range: 0 to 10,000 mm

Temperature

Accuracy: ± 1 °C

Resolution: 0.1 °C

Range:¹ -11 to 49 °C

Bulk Electrical Conductivity

Accuracy: ± 0.01 dS/m or $\pm 10\%$ (whichever is greater)

Resolution: 0.001 dS/m

Range: 0 to 120 dS/m (bulk)

¹If water freezes in the CTD sensor pressure transducer cavity, then ice formation will ruin the pressure transducer. If the sensor is in water, it must not be allowed to experience temperature below freezing, 0 °C or 32 °F.

General

Dimensions: 9 cm (l) x 3.4 cm (w)

Measurement Time: 300 ms (milliseconds)

Power Requirements: 3.6 to 15 VDC, 0.03 mA quiescent, 0.5 mA during 300 ms measurement

Output: Serial (TTL), 3.6 voltage levels or SDI-12

Operating Temperature: 0 to 50 °C

Connector Types: 3.5 mm (stereo) plug or stripped & tinned lead wires (Pigtail)

Cable Length: 10 m standard; custom cable length available upon request.

Data Logger Compatibility (not exclusive):

- **Decagon:** Em50, Em50R, Em50G
- **Campbell Scientific:** Loggers with serial I/O including CR10X, CR23X, any CRBasic type logger (CR850, 1000, 3000, etc.)
- **Other:** Any data acquisition system capable of 3.6 to 15 V Excitation and serial or SDI-12 Communication.

Handheld Reader Compatibility: ProCheck (rev 1.53+)

Software Compatibility: ECH2O Utility (rev 1.71+) or DataTrac 3 (rev 3.10+)

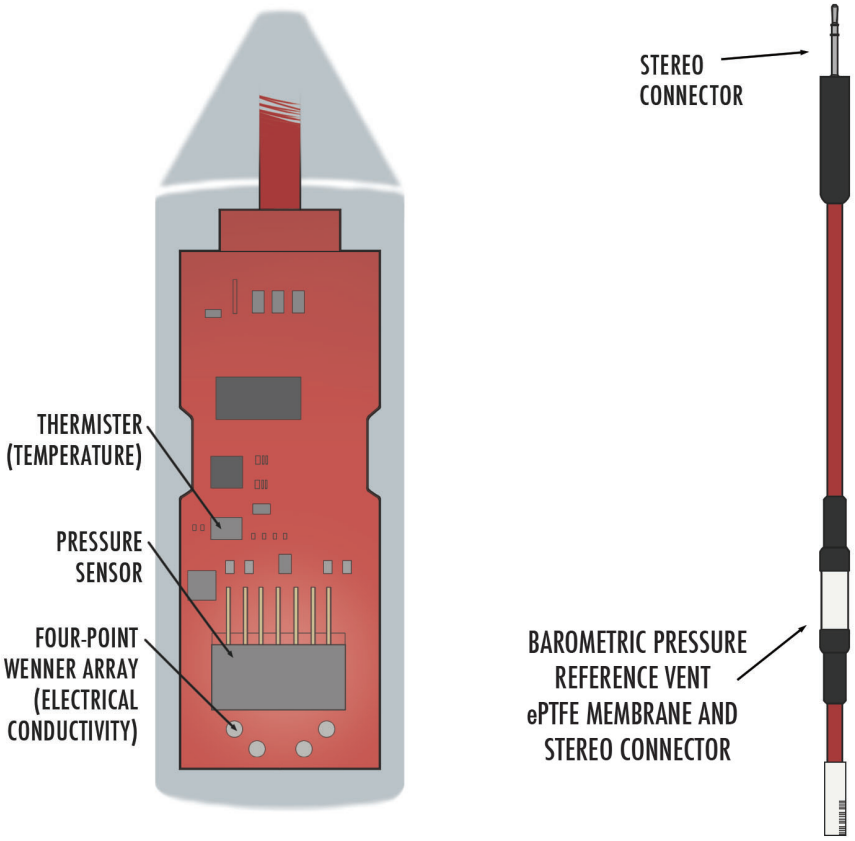

Figure 1: CTD Component Diagram

3 Theory

3.1 Water Depth

The CTD sensor uses a differential pressure transducer to measure the pressure applied by the water column above the sensor. The CTD uses a direct relationship between pressure and water depth to output water depth. The reference port of the pressure transducer is vented through the cable to atmospheric pressure, so the CTD requires no reference barometric pressure. A porous Teflon vent near the data logger end of the cable provides the reference. The Teflon keeps liquid water out of the cable, but allows air to enter and leave.

Keep this vent open to the same atmospheric pressure that applies to the water you are measuring. Since the cable conducts reference air between the sensor and the atmosphere, it is extremely important to protect the cable from any damage that allows water to enter.

3.2 Temperature

A thermistor near the electrical conductivity sensor senses the temperature of the water. The CTD uses the temperature to adjust the EC measurements to their 25 °C value and provides the temperature output for the data stream.

3.3 Electrical Conductivity

The CTD uses Electrical conductivity (EC) to measure the concentration of salts in the water and for information about dissolved solids. The CTD measures EC by applying an alternating electrical current to two electrodes, measuring the current flow through those electrodes, and then measuring voltage drop with a separate set of electrodes. The conductance is the ratio of current to voltage. Conductivity is conductance multiplied by a cell constant which is obtained using conductivity standards.

Note: A four electrode sensor gives unpredictable readings in air because there is no connection between the voltage and current electrodes.

4 Calibration

Decagon factory calibrates the water depth and EC sensors to values stored internally in flash memory. We calibrate the depth sensor in known depths of water and the EC sensor using KCl solutions of known concentrations.

Table 1 relates electrical conductivity at 25 °C to concentration for various concentrations of KCl. Operators can verify CTD EC sensor performance using the solutions in Table 1. The value outputs from the CTD Sensor are internally corrected to 25 °C.

Table 1: CTD Calibration Values

Electrical Conductivity ($\mu\text{S}/\text{cm}$)	g KCl/kg of distilled water
100	0.0446
200	0.0930
500	0.2456
1000	0.5120
2000	1.0673
5000	2.8186
10000	5.8758
20000	12.2490

5 Connecting Sensors

Power

Operators can power the sensor using any voltage from 3.6 to 15 VDC, but 12 V is optimal. The CTD sensor is an extremely low power sensor. When continuously powered, but not making a measurement or communication, it uses 30 μ A.

When using the sensor as part of an SDI-12 bus, it is recommended that the sensors be excited continuously to avoid issues with initial sensor startup interfering with the SDI-12 communications.

5.1 Connection

We designed the CTD Sensor to work most efficiently with Decagon's Em50, Em50R, Em50G data loggers, or our ProCheck handheld reader. The standard sensor (with 3.5 mm stereo connector) quickly connects to and is easily configured within a Decagon logger or ProCheck.

The Decagon CTD Sensor incorporates several features that also make it an excellent sensor for use with third party loggers. Customers may purchase the sensor with stripped and thinned wires (pig-tail) for terminal connections. Visit <http://www.decagon.com/support/literature> to get extensive directions on how to integrate the CTD Sensor into third party loggers

The Decagon CTD Sensor comes standard with a 10 meter cable. Customers may purchase sensors with custom cable lengths for an additional fee (on a per-meter basis). Decagon has tested its digital sensors successfully with up to 1000 meters (3200 ft) of cable. This option eliminates the need for splicing the cable (a possible failure point).

Connecting to an Em50/Em50R/Em50G Logger

Decagon designed the CTD to work specifically with Em50 Series

data loggers. Simply plug the 3.5 mm stereo plug connector directly into one of the five sensor ports. Next, configure the logger port for the CTD and set the measurement interval with ECH2O Utility.

Connecting to ECH2O Utility

Please check your software version to ensure it will support the CTD. To update your software to the latest version, please visit Decagon's software download site at www.decagon.com/support/downloads.

Note: You must use the ECH2O Utility, DataTrac 3 or a terminal program on your computer to download data from the logger to your computer.

5.2 Wiring



The following software supports the CTD sensor.

- ECH2O Utility 1.71 or greater
- ECH2O DataTrac 3.10 or greater

Connecting to a non-Decagon Logger

Customers may purchase CTD sensors for use with non-Decagon data loggers. These sensors typically come configured with stripped and tinned (pigtail) lead wires for use with screw terminals. Refer to your distinct logger manual for details on wiring. Our Integrator's Guide gives detailed instructions on connecting the CTD sensor to non-Decagon loggers. Please visit www.decagon.com/support/literature for the complete Integrator's Guide.

Pigtail End Wiring



Figure 2: Pigtail End Wiring

Connect the wires to the data logger as Figure 3 shows, with the supply wire (white) connected to the excitation, the digital out wire (red) to a digital input, the bare ground wire to ground. (Figure 2)

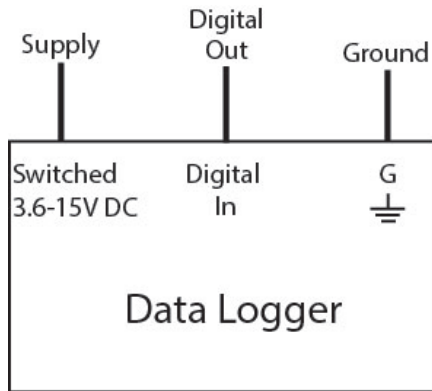

Figure 3: Wiring Diagram

Note: The acceptable range of excitation voltages is from 3.6 to 15 VDC. If you wish to read your Decagon sensor with the Campbell Scientific Data Loggers, you will need to power the sensors off of the switched 12V port.

If your CTD has the standard 3.5 mm plug and you want to connect it to a non-Decagon data logger, you have two options. First, you can clip off the plug on the sensor cable, strip and tin the wires,

and wire it directly into the data logger. This has the advantage of creating a direct connection with no chance of the sensor becoming unplugged; however, it cannot be easily used in the future with a Decagon readout unit or data logger.

The other option is to obtain an adapter cable from Decagon. The three wire sensor adapter cable has a connector for the sensor jack on one end, and three wires on the other end for connection to a data logger (many also know this type of wire as a “pigtail adapter”). Both the stripped and tinned adapter cable wires have the same termination (See Figure 2); the white wire is excitation, red is output, and the bare and blacks wires are ground.

6 Communication

The Decagon CTD sensor communicates using two different methods, Decagon serial stream or SDI-12 communication protocol. This section briefly discusses the specifics of each of these communication methods. Please visit <http://www.decagon.com/support/literature> for the complete Integrator's guide, which gives more detailed explanations and instructions.

6.1 Decagon Serial String

When you apply excitation voltage, the Decagon CTD sensor makes a measurement. Within about 1,000 ms of excitation three measurement values are transmitted to the data logger as a serial stream of ASCII characters. The serial out is 1,200 baud asynchronous with 8 data bits, no parity, and one stop bit. The voltage levels are 0 to 3.6 V and the logic levels are TTL (active high). You must remove power and reapply to transmit a new set of transmitted values.

The ASCII stream contains three numbers separated by spaces. The first number is water depth in mm, the second number is temperature in °C with a resolution of 0.1 °C, and the third number is EC in dS/m, with a resolution of 1 dS/m. A carriage return follows the three numbers, then the character “t,” indicating that this is a CTD sensor, then a checksum character and finally a carriage return and line feed.

6.2 SDI-12 communication

The CTD Sensor can also communicate using SDI-12 protocol, a three-wire interface where all sensors are powered (white wire), grounded (bare wire and black wire), and communicate (red wire) on shared nodes (for more information on the SDI-12 protocol, visit www.sdi-12.org). Below is a brief description of SDI-12 for communication with the CTD Sensor, please see our Integrator's Guide at www.decagon.com/support/literature for detailed instructions.

SDI-12 Commands

Table 2 lists SDI-12 commands for the CTD Sensor. The sensor address is ‘a.’ If you substitute a ‘?’ for ‘a’ all addresses respond.

Table 2: SDI-12 Commands for CTD

Send Identification	a!	a13DECAGON CTD 316<CR><LF>
Change Address	aAb!	b<CR><LF>(b is new address)
Address Query	?!	a<CR><LF>
Start Measurement	aM!	00013<CR><LF>
Send Data	aD0!	a+9+22.2+0<CR><LF>(3 values)

SDI-12 Sensor Bus

Operators can connect up to 62 sensors to the same 12 V supply and communication port on a data logger. This simplifies wiring because no multiplexer is necessary. However, one sensor problem can bring down the entire array (though a short circuit or incorrect address setting). If you use an SDI-12 sensor bus, we recommend that you make an independent junction box with wire harnesses where all sensor wires attach to lugs so sensors can be disconnected individually if a problem arises. You can run a single three-wire cable from the junction box to the data logger.

SDI-12 Address

The SDI-12 protocol requires that all sensors have a unique address. CTD Sensors come from the factory with an SDI-12 address of 0. To add more than one SDI-12 sensor to a system, you must change the sensor address. Address options include 0...9, A...Z, a...z. The best and easiest way to change an address is to use Decagon’s ProCheck (if the option is not available on your ProCheck, please upgrade to the latest version of firmware). SDI-12 addressing can be accessed in the CONFIG menu by selecting “SDI-12 Address.” Addresses may

then be changed by simply pressing the up or down arrows until you see the desired address and pushing Enter.

The SDI-12 communication protocol is supported by Campbell Scientific data loggers like the CR10X, CR200, CR10000, CR30000, etc. Direct SDI-12 communication is supported in the “Terminal Emulator” mode under the “Tools” menu on the “Connect” screen. Detailed information on setting the address using CSI data loggers can be found on our website at <http://www.decagon.com/support/downloads>.

7 Installation

Operators can install the Decagon CTD Sensor in wells 3.5 cm diameter or larger. We designed the CTD for use in groundwater monitoring wells or piezometers, surface water monitoring, and wetland monitoring. It is important to use properly designed wells to obtain accurate data and for proper sensor operation.

Proper well installation

Hydrology studies using monitoring wells or piezometers are only as good as the well installation permits, regardless of the type of sensor you use. Well design depends on the desired measurement, whether it is groundwater flow, quality, level, or pressure head. Read “Installing Monitoring Wells in Soils” to learn about how to properly install a monitoring well or piezometer.²

Down-well Sensor Installation

The Decagon CTD sensor can be installed down a well by suspending the sensor at the desired depth in the well. When deciding on how deep to install the CTD sensor several things need to be considered. It is best to keep the sensor under water at all times in order to ensure measurements are continuous. The range of the sensor also needs to be considered. The maximum measurement depth of the CTD-10 depth is 10 m. If the water level rises above this level you will not get accurate water depth readings and can potentially damage the sensor.

If water freezes in the CTD sensor pressure transducer cavity, the pressure transducer will be permanently and catastrophically damaged by the ice formation. If the sensor is in water, it must not be allowed to experience temperatures below 0 °C or 32 °F.

²Sprecher, S.W. 2008. “Installing Monitoring Wells in Soils” (Version 1.0). National Soil Survey Center, Natural Resources Conservation Service, USDA, Lincoln, NE. You may find this publication at: <http://www.decagon.com/wellinstallation>

Freezing is not generally a problem in deep underground well installations, but might be an issue in surface water wells and underground installations above the frost depth.

Note: Exposing the CTD sensor to freezing temperatures with water in the pressure transducer cavity voids the sensor warranty.

7.1 Taking a Reading

Customers may find an example program from Edlog and CRBasic in our software section online at <http://www.decagon.com/support/downloads>. As with the Decagon Serial String, the water depth is the first number output by the sensor, in mm. The second number is temperature in Celsius. The third number is electrical conductivity in μ S/cm.

8 Maintenance and Troubleshooting

8.1 EC Sensor Cleaning

A four electrode conductivity measurement is less sensitive to sensor fouling than a two electrode sensor, but contamination of the electrodes can still affect the measurement. The electrodes are stainless steel.

Cleaning Method

1. Insert swab into slot on side of sensor housing. Rub the screws vigorously with swab.

Note: Take care not to damage pressure sensor with swab.

2. Rinse the sensor and screws thoroughly with tap or Distilled Water

Note: Be sure not to touch the screws without gloves or to contact them with any source of oil or other non-conducting residue.

8.2 Troubleshooting

Most problems with the CTD Sensor relate to incorrect or erroneous readings. Before contacting Decagon about sensor malfunctions, follow the data logger and sensors troubleshooting steps.

Data Logger

1. Check to make sure the connections to the data logger are both correct and secure.
2. Ensure the data logger batteries are not dead or weakened.
3. Check the configuration of the data logger in ECH2O Utility or DataTrac to make sure you have selected the CTD Sensor.
4. Ensure that you are using the most up to date software and firmware. You can find the most up to date version of the software and firmware at <http://www.decagon.com/support>.

Sensor

1. Ensure that your sensors are installed according to Section 7 “Installation.”
2. Check sensor cables for nicks or cuts that could cause a malfunction.

9 Declaration of Conformity

Application of Council Directive: 2004/108/EC and 2011/65/EU

Standards to which conformity is declared: EN 61326-1:2013 and
EN 50581:2012

Manufacturer's Name: Decagon Devices, Inc. 2365 NE
Hopkins Ct. Pullman, WA 99163
USA

Type of Equipment: Water Depth Sensor

Model Number: CTD-10

Year of First Manufacture: 2012/2014

This is to certify that the CTD manufactured by Decagon Devices, Inc., a corporation based in Pullman, Washington, USA meets or exceeds the standards for CE compliance as per the Council Directives noted above. All instruments are built at the factory at Decagon and pertinent testing documentation is freely available for verification.

Index

- Calibration
 - Values, 3, 8
- CE Compliance, 20
- Cleaning Method, 18
- Connecting
 - ECH2O Utility, 10
 - Em50 Series Data Logger, 9
- Contact Information, 1
- Declaration of Conformity, 20
- ECH2O Utility, 10
- Electrical Conductivity, 3
 - Bulk, 3
- Email, 1
- Fax, ii
- Installation, 16
 - Down Well, 16
- Integrator's Guide, 10
- Logger
 - Communications, 11
 - Non-Decagon, 10
- Power, 4, 9
- SDI-12 Address, 14
- SDI-12 Commands, 14
- SDI-12 Communication, 9
- SDI-12 Sensor Bus, 14
- Seller's Liability, 2
- Specifications, 3
- Temperature, 6
- Troubleshooting
 - Data Logger, 18
 - Sensor, 19
- Warranty, 1
- Water Depth, 6
- Wiring
 - Pigtail, 11
 - Stereo Plug, 10